

QoS as a Business Case for Access Networks

Presentation of paper “QoS as the tool for enabling Broadband commodity within Access Networks”.

Authors

- Andreas Foglar, Infineon Technologies > Presenter
- Enrique Areizaga, Robotiker-tecnalia
- Antonio J. Elizondo, Telefonica I+D



Never stop thinking

Problem of Access Network Operators

- High investment cost CAPEX
 - Example Deutsche Telekom: ca. 20.000 DSLAMs
- High operational cost OPEX
- Bounded income with flat rate
 - Example
 - Rent of copper cable pair: 10€ / month
 - Flat rate 2Mb/s: 15€ / month
 - Upstream increase to 0.5Mb/s: 1€ / month
 - VoIP: 2ct ... 26ct / minute > ca. 20€ / month
 - 2 web communities: 18€ / month
 - Total: 64€ / month

Possible Relief: QoS Business Case

■ Additional flat rate for guaranteed bandwidth and security

□ Example

- ↪ Rent of copper cable pair: 10€ / month
- ↪ Flat rate 2Mb/s: 15€ / month
- ↪ Upstream increase to 0.5Mb/s: 1€ / month
- ↪ **QoS flat rate: 5€ / month**
- ↪ VoIP: 2ct ... 26ct / minute > ca. 20€ / month
- ↪ 2 web communities: 18€ / month
- ↪ Total: 69€ / month

□ ~ 10% more cost for subscriber

□ ~ 30% more income for operator

PLANETS QoS classes subscriber perception

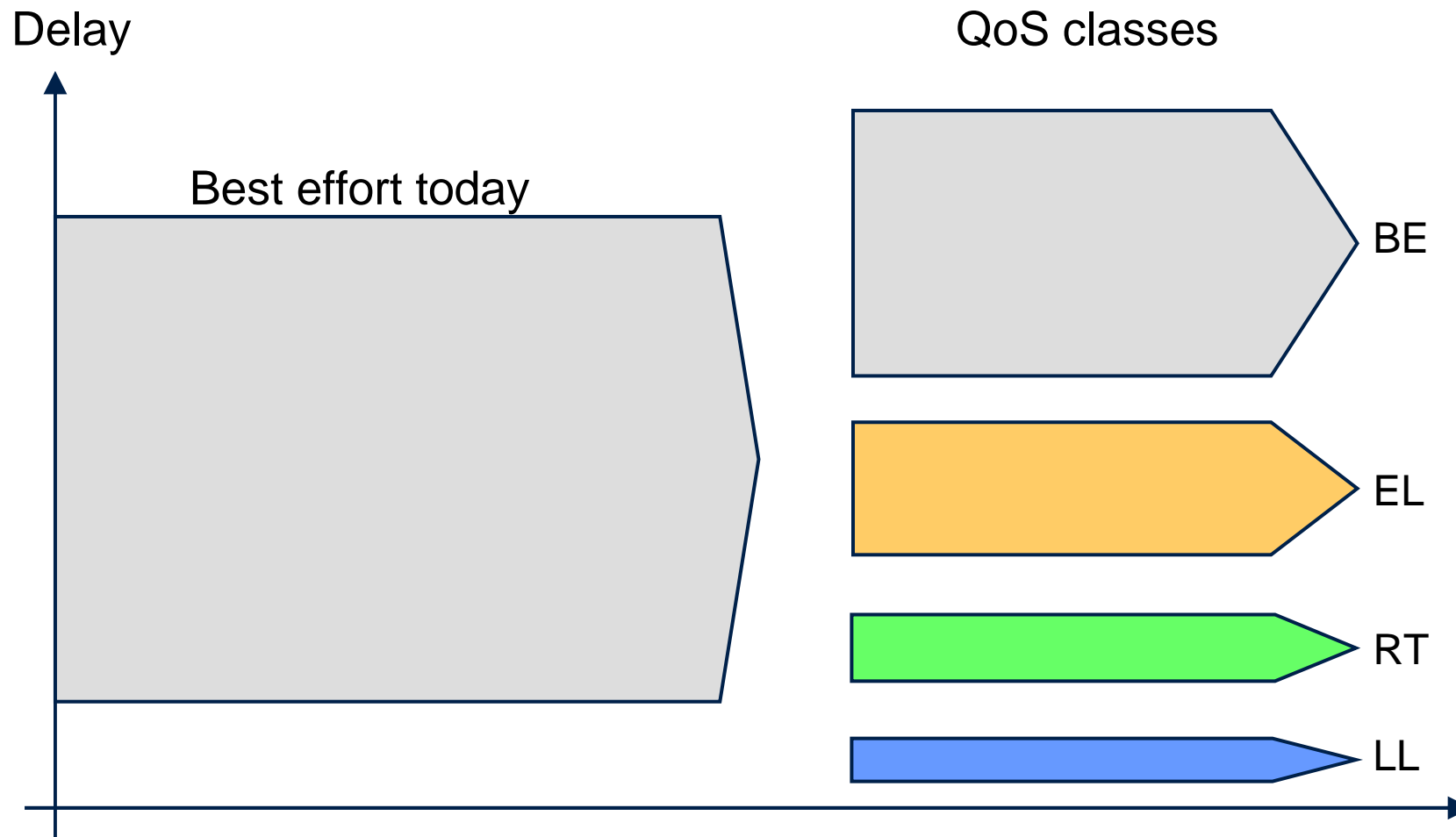

End-to-end delay example: Streaming Maximum delay applies (de-jitter buffer)



| Max. delay | LL Class | | RT Class | | EL Class | |
|------------|----------|--|----------|--|----------|--|
| 100km | 5 ms | | 99 ms | | 2979ms | |
| 1000km | 10ms | | 103ms | | 2983ms | |
| 10000km | 55ms | | 148ms | | 3028ms | |

PLANETS QoS allows exact calculation.

Parameters:

- 10 Nodes
- Upstream 2 Mb/s
- Downstream 10 Mb/s

**Application example:
Interactive language learning video
> Frequent rewind necessary**

End-to-end delay example: Interactive

Mean delay is experienced



| Mean delay | LL Class | | RT Class | | EL Class | |
|------------|----------|------|----------|------|----------|-------|
| 100km | | 3 ms | | 19ms | | 339ms |
| 1000km | | 7 ms | | 23ms | | 343ms |
| 10000km | | 52ms | | 68ms | | 388ms |

PLANETS QoS allows exact calculation.

Parameters:

- 10 Nodes
- Upstream 2 Mb/s
- Downstream 10 Mb/s

**Application example:
Remote computing
> Instant drop-down menus needed**

Proven Solution available

- Concepts from MUSE, implemented and verified in PLANETS
- QoS solution mature (www.medea-planets.eu/QoSsolution.php)
 - 4 classes
 - Compliant with DiffServ, Ethernet QoS, HGI
 - CAC algorithms available
- Interface to resource reservation subsystem (RACS) of IMS
- Access node configuration extension
- Adaptation of Border Gateway
- All functions verified in T-Systems Lab trial
 - Extensive measurements: bit error rate and MOS values (>4)

QoS Pipe Concept (Service Connection)

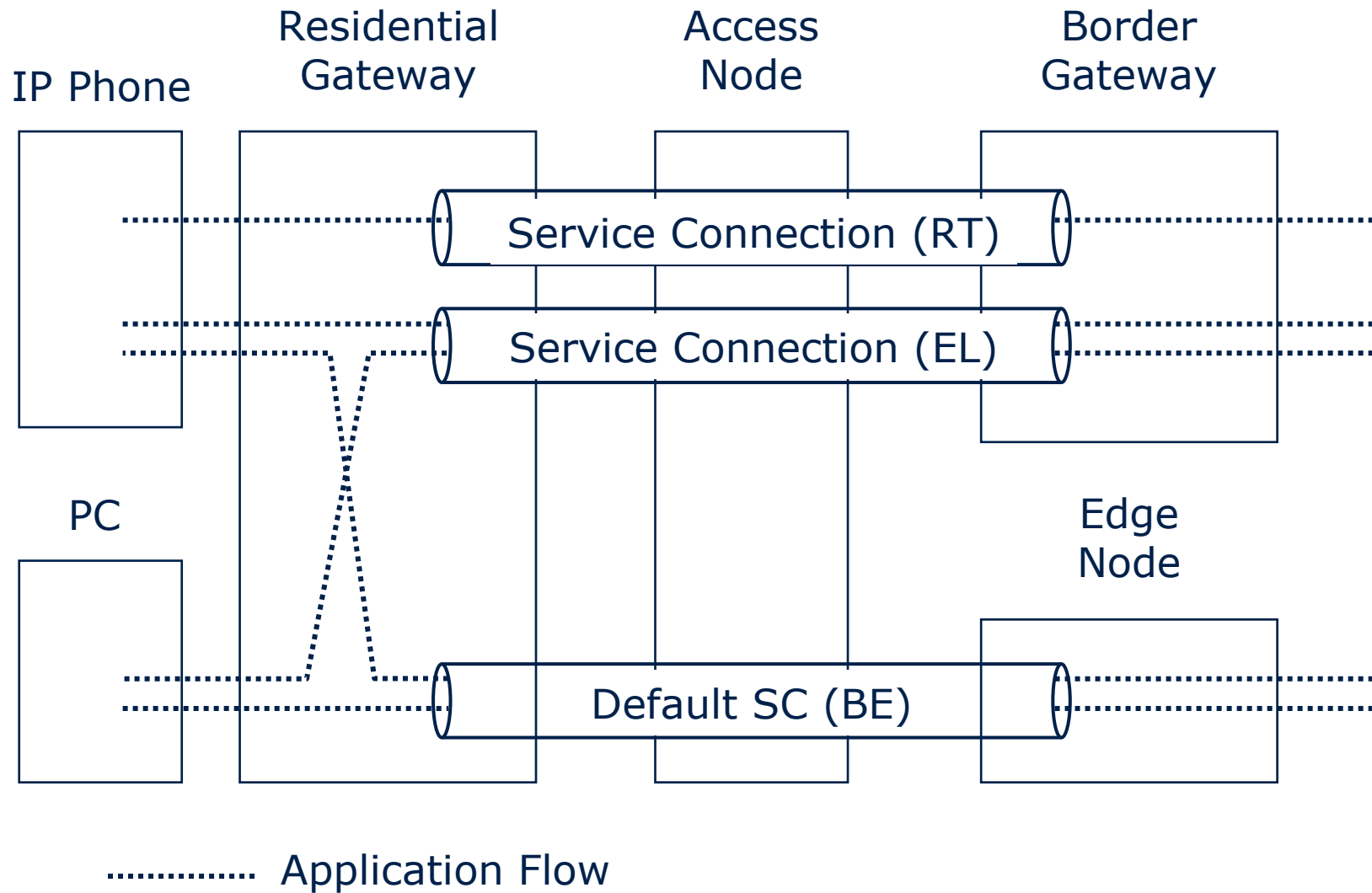

Border Gateway adaptation

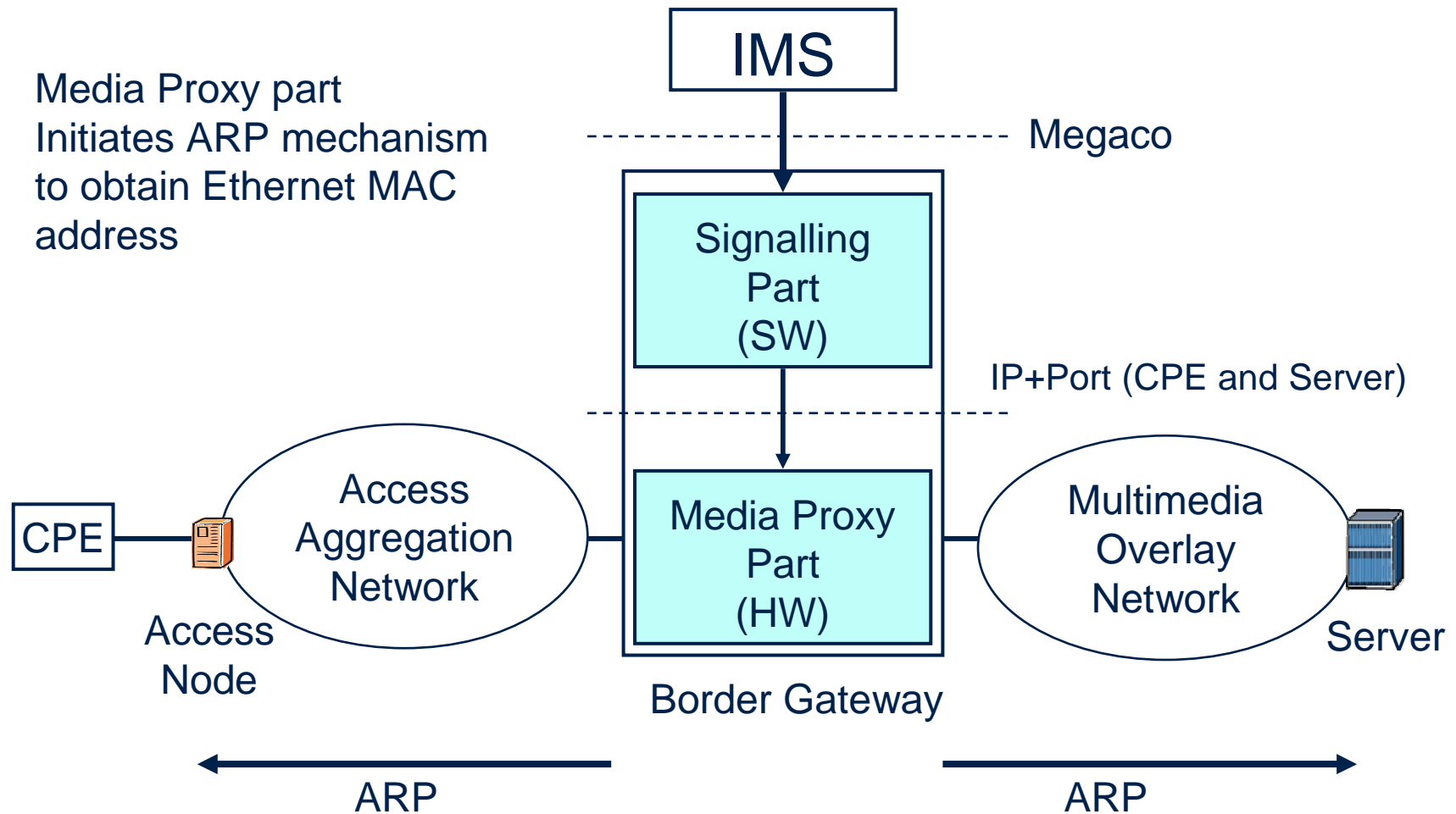

Media Proxy part
Initiates ARP mechanism
to obtain Ethernet MAC
address

PLANETS Lab trial set-up

Access Node

- supports Layer-2 switching and IP forwarding on Layer-3
- IP forwarding is not routing but switching using IP addresses
 - Better Layer-2 security
 - QoS on IP layer
 - Better scalability
 - Higher layer functionality easier to integrate (RACS)
- Uplink: Gigabit Ethernet
- Downlink: VDSL2
- End-user authentication based on IEEE 802.1X

videophone

Switch

Aggregation network with RACS

- Flexible linux-based Ethernet-Switch platform
- QoS managed by a Resource and Admission Control System (RACS)
- Interoperation with IMS

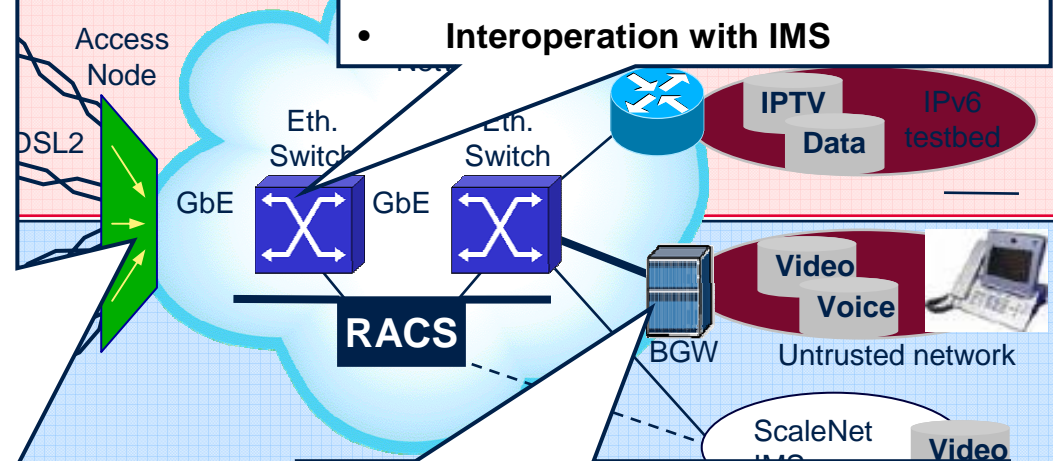

Border Gateway

- Separates different packet network domains on transport layer while allowing applications to transit
- Analyzes SIP messages to set up and release QoS controlled media paths through the gateway
- ConverGate processor for media path handling

PLANETS QoS measurement example

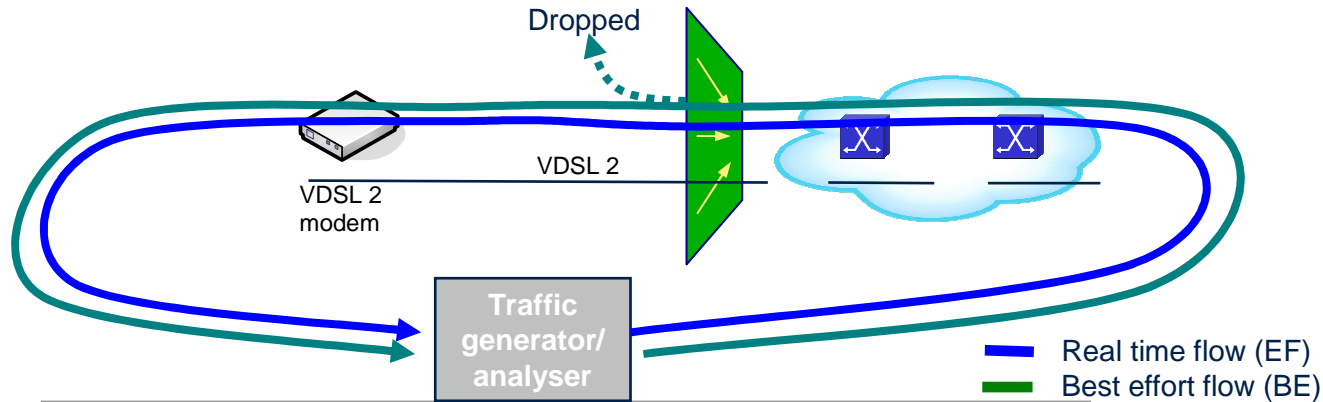

Avg. Latency/ μ s

Avg Latency (μ Sec)

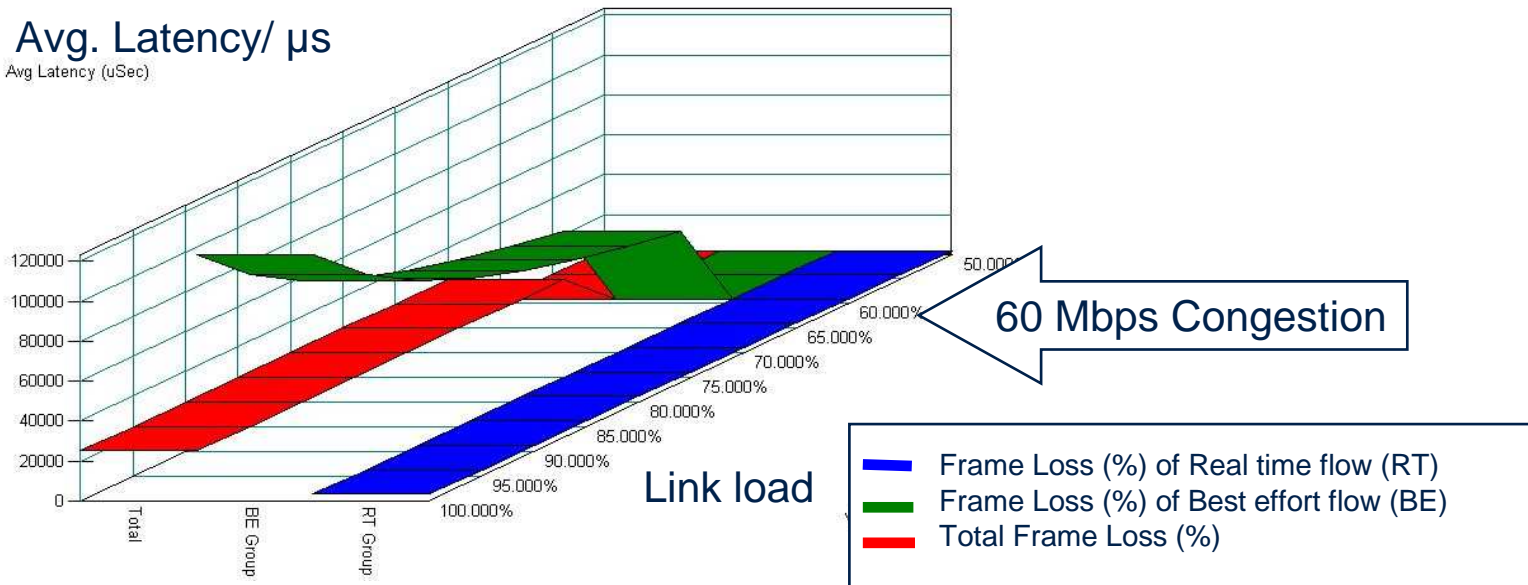

Business Case: Investment

1. Configuration of QoS Pipes for Access Node
 - FW/SW update
2. Provisioning of QoS Pipes in Access Nodes
 - Parameters: guaranteed rate (in steps of 100kb/s), subscriber- and server identification
 - Additional rules in provisioning system
3. Provide interface to signaling system (IMS)
4. Add Border Gateway
 - One SBC for 100.000 subscribers
 - Upgrade upon service acceptance

Note: Border Gateway also called Session Border Controller SBC

Summary and Next Steps

Summary

- QoS for subscribers is a potential additional business case for Access Network operators
- Technology is mature and proven
- QoS support can be added to Ethernet-based access networks at low initial investment
 - Gradual upgrade upon customer acceptance

Next Steps

- Field trial
- Small scale deployment (e.g. city network)
- Public funding possible (e.g. SSA from EU)

Thank you for your
attention

Questions?



Never stop thinking

MUSE Consortium



www.ist-muse.org

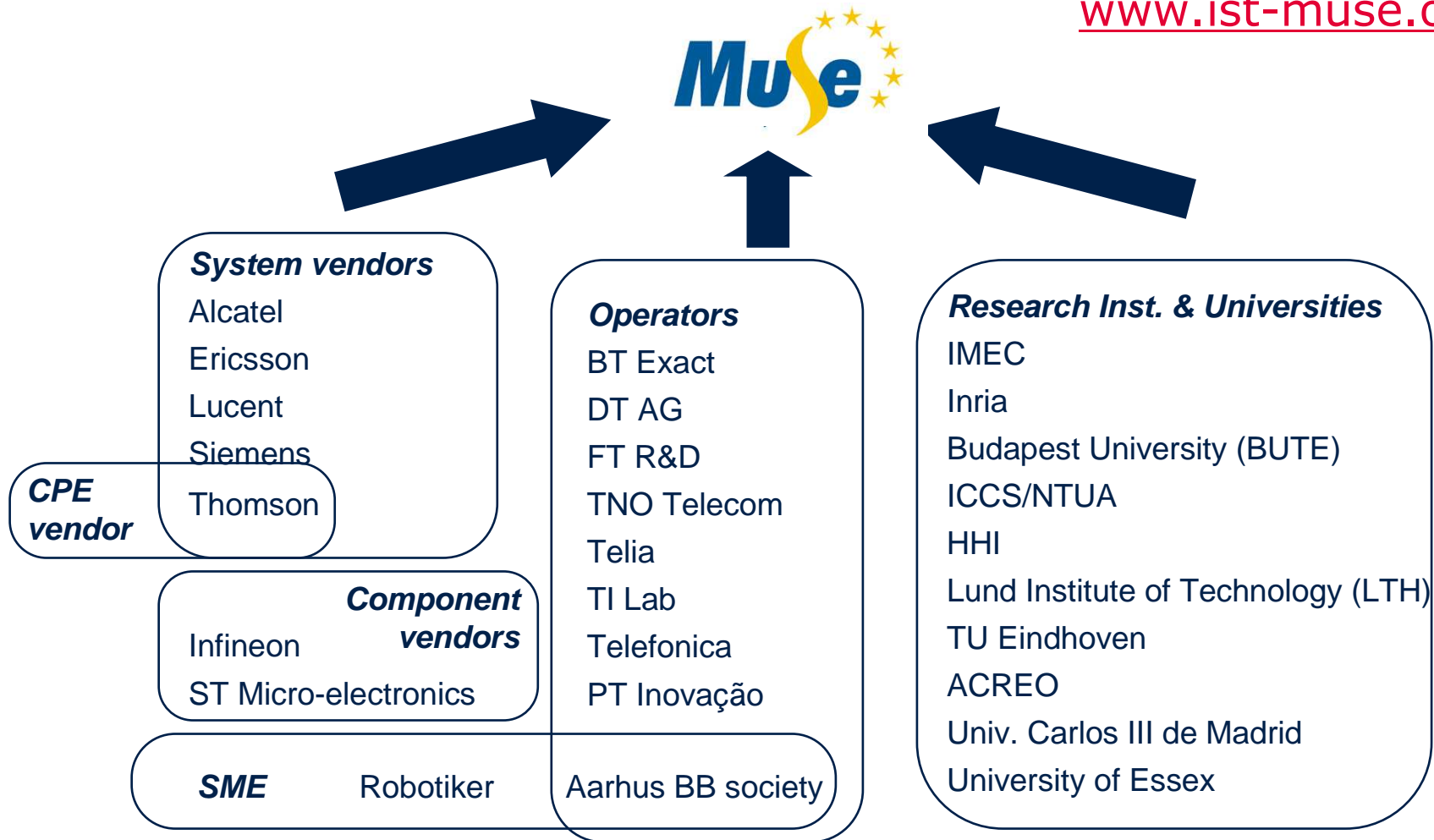

MUSE Results

- Set of specifications >> GSB (Global System for Broadband)
- Some QoS rules from MUSE
 - Resource control (CAC)
 - QoS needs end-to-end consideration, but ...
 - ... complex QoS methods for low rate links
 - ... simple QoS for the backbone.
 - 4 QoS classes
 - Time behavior as differentiating parameter
- Other rules
 - No signaling in the Access Node!

Project A121 PLANETS

- Platform for Networked Services
- Programme: Medea+
 - part of Eureka framework
- Area: High speed communication networks
- Scope: network access
 - from terminal to core network border
- 18 partners from 4 countries
- 3 years run time 2005 – 2007
- total 212 PY
- www.medea-planets.eu



THALES

robotiker
tecnalia

PHILIPS

NXP
founded by Philips

...T...Com...

...T...Systems...



Alcatel-Lucent



Telefonica



We commit.

We innovate.

We partner.

We create value.



Never stop thinking