

## QoS in the Next Generation Networks

**Pascal LORENZ**  
lorenz@ieee.org

Pascal LORENZ

---

---

---

---

---

---

---

---

## Quality of Service

- QoS for a network: different parameters such as bandwidth, latency, jitter, packet loss, packet delay
- for video applications: QoS is based on the bandwidth
- for VoIP: QoS is based on latency (end to end delay not larger than 200 ms)
- =>optimize delay, bandwidth, packet loss... but not all

Pascal LORENZ

---

---

---

---

---

---

---

---

- CoS (Classes of Service) classify the services in different classes.
- CoS manage each type of traffic with a particular way
- ETSI (European Telecommunications Standards Institute) has introduced 4 CoS (Classe 1 : Best Effort, Classe 4: QoS guaranteed)
- QoE (Quality of Experience): subjective measure of a customer's for a supplied service
- Many SLA offers 3 CoS: Premium (max 15% of network resources), Olympic (max 80% of network resources) and BE

Pascal LORENZ

---

---

---

---

---

---

---

---

- QoS can be linked to the
  - network level: QoS depend of the network policy. Mechanisms such as filters, rerouting in the core of the network and control access at the corners of the network. Intelligence in the routers. (OSPF, RIP, SNMP, BGP)
  - application level: applications which improve the QoS. No link with the network infrastructure. (NFS, ...)

Pascal LORENZ

---

---

---

---

---

---

---

---

- Signaling at the application level: SIP, H323
- Signaling at the network level: COPS, RSVP

Pascal LORENZ

---

---

---

---

---

---

---

---

- **Internet is increasing exponentially:**
  - **2001: 180 million users**
  - **today: more than 1,2 billions users**
- **Internet traffic and the bandwidth double every 18 months**
- **The bandwidth is about 35 Tbits/s**
- **More wireless voice traffic than wired traffic**
- **=> non-packet based traffic are encapsulated in data packet traffic (Internet)**
- **=> Multiple access technologies (ADSL, 3G, ...)**

Pascal LORENZ

---

---

---

---

---

---

---

---

- integration of QoS mechanisms is more easy in small networks, because large networks ingrate a lot of heterogeneous domains
- Internet 1: will still exist
- Internet 2: QoS during all the communication. MPLS
- IPv4: introduce intelligence in the nodes
- IPv6: use the intelligence of the PC

Pascal LORENZ

---

---

---

---

---

---

---

---

- CTI (Computer telephony Integration)
  - PC: intelligence in the computer
  - telephony: intelligence in the network
  - => to reach a compromise
- Switched telephony network (TDM) => IP NGN networks (Multiservices Convergent Network)
- Modem triple play (voice, data, TV)
- Quadruple play: triple play + mobile telephony
- IMS (IP Multimedia System) architecture: full IP architecture

Pascal LORENZ

---

---

---

---

---

---

---

---

## New Communication architecture

- Challenge : offer QoS in the Internet network
- Multimedia applications, VoD, IPTV for Internet will be developed and used when QoS mechanisms will exist
- New functions must be developed to guarantee performance, offer security, avoid jitter, allow the respect of time-constraints, ...

Pascal LORENZ

---

---

---

---

---

---

---

---

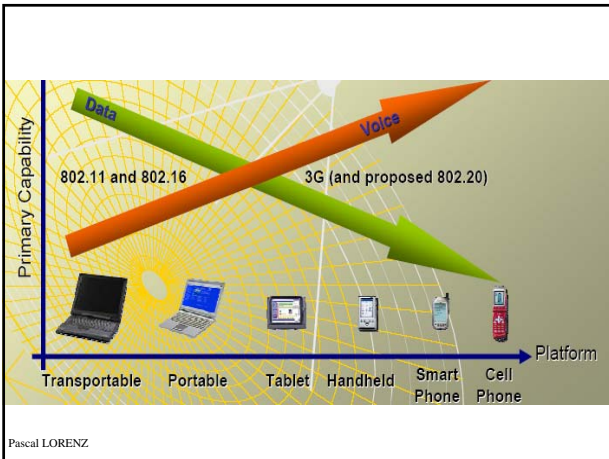

---

---

---

---

---

---

---

---

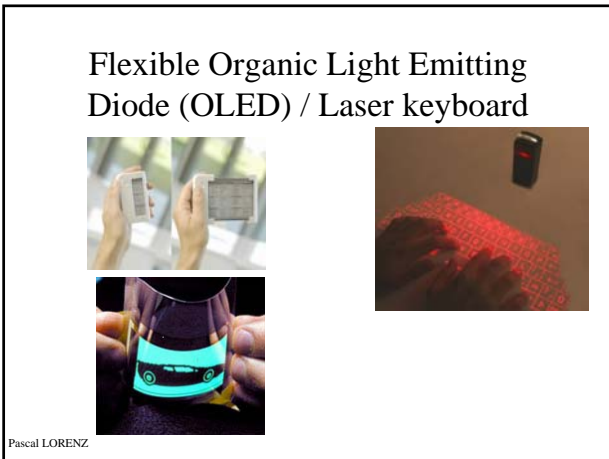

---

---

---

---

---

---

---

---

- 2 types of applications: elastic (TCP) or streaming (RTP/UDP)
  - 90% TCP - 10% UDP (no congestion control mechanisms)
  - WWW: 75%      Email: 3%
  - FTP: 4%        News: 7%
- Pascal LORENZ

---

---

---

---

---

---

---

---

- Best Effort: provide a fair service
- Max-min allocation of bandwidth: maximize the bandwidth allocation to the source receiving the smallest allocation  
=> decrease the bandwidth allocated to other source
- Packets are dropped when congestion occurs in routers
  - when the buffer is full (tail drop)
  - when the buffer occupancy increases too much (RED Random Early Detection)

Pascal LORENZ

---

---

---

---

---

---

---

---

- Congestion control mechanisms in end systems
  - Inform the source about network congestion with ICMP or tagged packets with ECN (Explicit Congestion Notification) => all routers should implement the congestion control mechanisms
- Divide the output buffers in N queues and introduce a scheduler (processor sharing, round robin)

Pascal LORENZ

---

---

---

---

---

---

---

---

- Classification of the IP flows at different layers: edge router perform classification/marketing and backbone router relies on marking
- Weighted RED: n RED algorithms in parallel. Support n drop priorities to offer minimum bandwidth service
- Generalized Processor Sharing/Weighted Round Robin: introduce a weight to each queue

Pascal LORENZ

---

---

---

---

---

---

---

---

- New communications network must offer:
  - QoS
  - Mobility
- => necessary to introduce
  - QoS mechanisms with signaling and routing solutions (telecommunication world)
    - Switching: distributed (MPLS) or centralized (PDP)
  - Overprovisioning/priority the network for new applications such as TV on demand, telephony IP
    - Routing
- Overprovisioning is not a global solution but is an asset for traffic engineering and QoS in Internet

Pascal LORENZ

---

---

---

---

---

---

---

---

- Core of the network: architectures with signaling (SS7, X25/ATM, GSM, UMTS, NGN): QoS but expensive => UMTS 15000 \$
- with no signaling (Arpanet, Internet 1<sup>st</sup> and 2<sup>nd</sup> generation, WiFi): no QoS, but cheap => Wi-Fi 100 \$

Pascal LORENZ

---

---

---

---

---

---

---

---

- Routing: giga/tera routers or priority mechanisms
- Switching (optical, temporal, space): centralized signaling (policy control) or decentralized signaling (MPLS).

Pascal LORENZ

---

---

---

---

---

---

---

---

- Reservation of resources
  - hard state: complex because signaling is necessary, modification is complex
  - soft state: destruction of the route is done automatically, refreshment to keep a route, easy to change the route
- 1<sup>st</sup> generation Internet: Best Effort
- 2<sup>nd</sup> generation Internet: QoS, mobility, security
  - all IP with terarouter
  - Use the networks providing QoS (ATM, MPLS, ...):VC, switching environment
- 3<sup>rd</sup> generation: common architecture for wire and wireless communications

Pascal LORENZ

---

---

---

---

---

---

---

---

- Growth of the networks capacity: Wavelength Division Multiplexing (WDM)
  - 2005: 1000 Wavelength / 100 Tbit
  - optical switching
  - ATM cannot work with these rate
  - IP packet => IP frame (code violation)
  - IP over ATM over IP
  - all IP in the future Copper => optical
- 3<sup>rd</sup> generation
  - Intelligent platform with several IP WDM network

Pascal LORENZ

---

---

---

---

---

---

---

---

- Fiber To The Curb (FTTC)
- Fiber To The Building (FTTB)
- Fiber To The Home or (FTTH)
- Fiber To The Terminal ou (FTTT)

Pascal LORENZ

---

---

---

---

---

---

---

---

Technology	Distance max	Rate max
HDSL (High bit DSL)	5 km	2 Mbit/s
UDSL (Universal DSL)	6 km	2 Mbit/s
SDSL (Single DSL)	3 km	2 Mbit/s
ADSL (Asymmetric DSL)	6 km	- 1 Mbit/s (download)/ 16 kbit/s (upload)
	4 km	- 8 Mbit/s (download)/ 640 kbit/s (upload)
VDSL (Very high DSL)	1,5 km	- 13 Mbit/s (download) / 1,5 Mbit/s (upload)
	0,3 km	- 52 Mbit/s (download) / 2,3 Mbit/s (upload)

Pascal LORENZ

---

---

---

---

---

---

---

---

---

---

### Mechanisms for QoS:

- ATM or IP. Each solution has his own advantage and offer different QoS guaranties
- IP networks are technically and economically reliable
- 2nd generation of Internet introduce signaling and QoS (IntServ, DiffServ, MPLS, IPv6, ...)
- Need of metrics for QoS
  - Necessary for SLA (Service Level Agreements) between a provider and a client)
- IPPM (IP Performance Metric)

Pascal LORENZ

---

---

---

---

---

---

---

---

---

---

### ATM networks

- Connection oriented protocol
- offer real QoS guaranty
- QoS is negotiated during the establishment of the connection and depend of the available resources

Pascal LORENZ

---

---

---

---

---

---

---

---

---

---

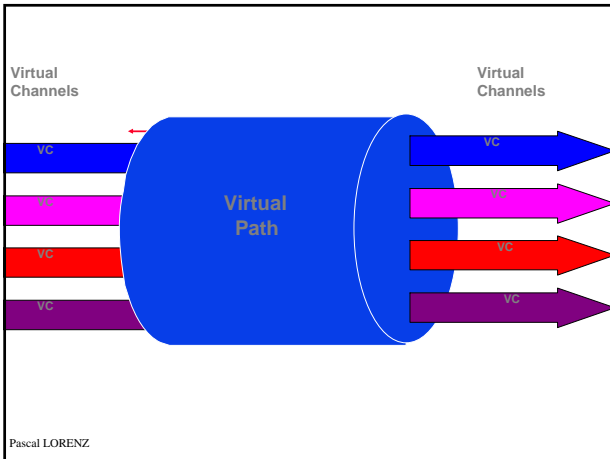

---

---

---

---

---

---

---

---

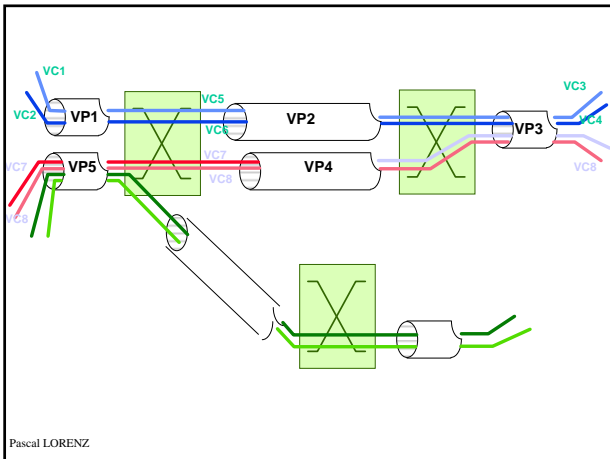

---

---

---

---

---

---

---

---

- 6 CoS:
    - CBR(Constant Bit Rate): guarantee a constant rate: videoconferencing, telephony
    - RT-VBR (Real-Time Variable Bit Rate): transmission with a variable rate for application requiring real-time constraints: MPEG transmission
    - NRT-VBR (Non-Real-Time Variable Bit Rate): transmission with a variable rate for application requiring no real-time constraints: multimedia transfer
    - ABR (Available Bit Rate): transmission of traffic using remaining bandwidth or bursty traffic. ABR guaranty always a minimum rate.
- Pascal LORENZ

---

---

---

---

---

---

---

---

- GFR (Guaranteed Frame Rate): accept to loose sometime some services
- UBR (Unspecified Bit rate): no rate guaranty and no congestion indication. Best Effort.

Pascal LORENZ

---

---

---

---

---

---

---

---

CBR

RT-VBR

NRT-VBR

UBR

ABR

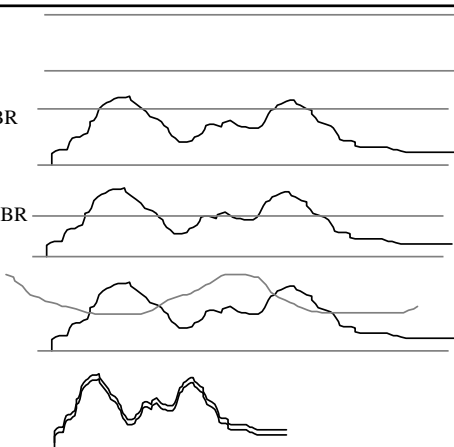

Pascal LORENZ

---

---

---

---

---

---

---

---

- For these CoS, 5 AAL (ATM Adaptation layer) have been defined:
  - AAL1: for real-time traffic. Oriented connection. CBR
  - AAL2: variable real time traffic. VBR
  - AAL3/4: variable real-time traffic. ABR, GFR
  - AAL5: user can choose between reliable or non-reliable services, can do unicast or multicast traffic

Pascal LORENZ

---

---

---

---

---

---

---

---

## Parameters

- QoS comes from the signaling mechanisms and stream controls
- QoS parameters are:
  - CTD: Cell Transfer Delay
  - CMR Cell Misinsertion Ratio
  - CLR: Cell Loss Ratio
  - CER: Cell Error Ratio
  - PCR Peak Cell Rate
  - MCR: Minimum Cell Rate
  - CVDT: Cell variation Delay Tolerance
  - SCR: Sustainable Cell Rate
  - BT: Burst Tolerance
  - CDV: Cell Delay Variation

Pascal LORENZ

---

---

---

---

---

---

---

---

## Stream control

- CAC (Connection Admission Control) determines if a connection can be accepted or not
- UPC/NPC: Usage Parameter Control/Network Parameter control. Manage and control the traffic and the conformity of a connection
- RM: Resource Management. Optimize the traffic

Pascal LORENZ

---

---

---

---

---

---

---

---

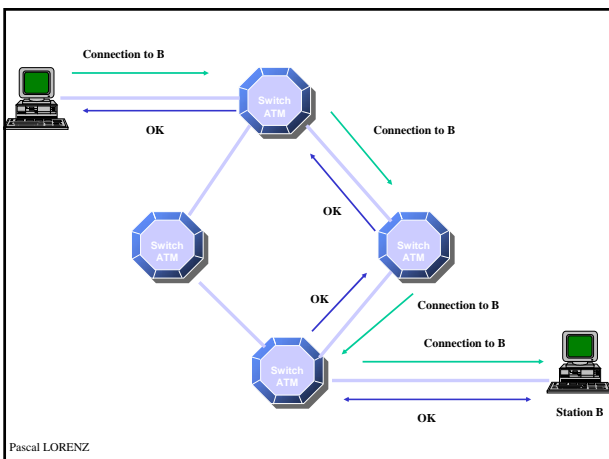

Pascal LORENZ

---

---

---

---

---

---

---

---

## IP over ATM

- LANE: LAN Emulation
- Classical IP
- MPOA: Multi Protocol Over ATM

Pascal LORENZ

---

---

---

---

---

---

---

---

## Classical IP

- Defined by IETF
- Introduce the notion of LIS (Logical IP Subnetwork): emulation of a IP subnetwork
- each IP station registers a connection with an ARP (Address Resolution Protocol) Server.
- The ARP server do the translation between IP and ATM addresses
- Multicast traffic: MARS (Multicast Address Resolution Server)

Pascal LORENZ

---

---

---

---

---

---

---

---

- Problems:
  - Only IP is supported
  - the connections between 2 ARP servers must be done through protocols such as NHRP (Next Hop Resolution Protocol)

Pascal LORENZ

---

---

---

---

---

---

---

---

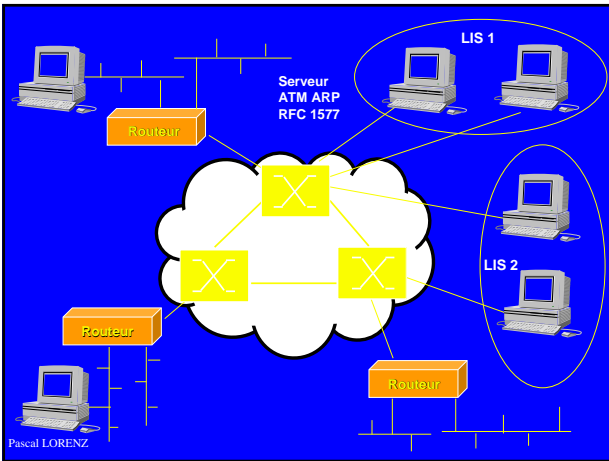

---

---

---

---

---

---

---

---

## LANE

- Support all types of protocol (IP, IPX, ...)
- Problem: cannot be used for wide area networks, routers are always necessary

Pascal LORENZ

---

---

---

---

---

---

---

---

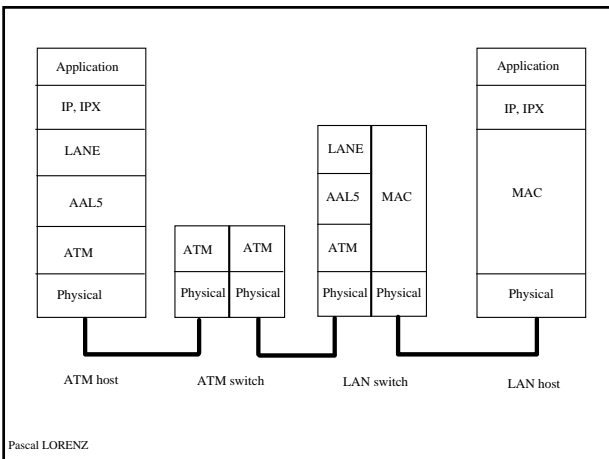

---

---

---

---

---

---

---

---

- Composed by 3 servers and 1 client:
  - LEC (LAN Emulation Client): station with an ATM address and a MAC address
  - LES (LAN Emulation Server): for the translation between the 6 octets of the IP address and the 20 octets of the ATM address
  - LECS (LAN Emulation Configuration Server): automatic configuration. Allow to know the LES ATM address
  - BUS: Broadband Unknown Server. Management of multicast, broadcast and unknown frames.

Pascal LORENZ

---

---

---

---

---

---

---

---

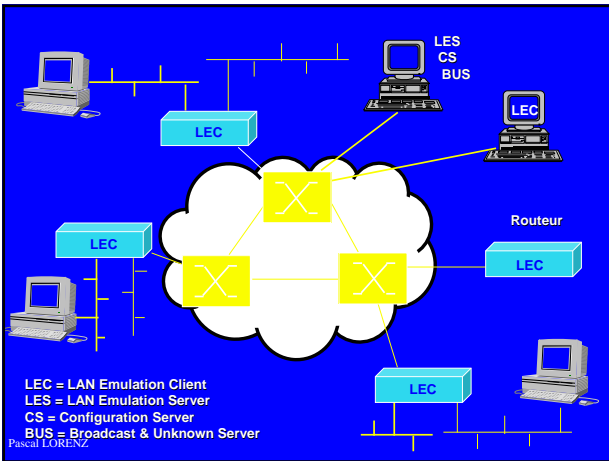

---

---

---

---

---

---

---

---

## MPOA

- avoid the router bottleneck problem
- introduce a route server used for the ATM address resolution
- can be considered as a virtual router which divide data transmission from computation functions
- I-PNNI is used instead of RIP and OSPF
- MPOA can be used in wide area network
- Router: + Intelligence - slow
- Switch: + speed - no intelligence

Pascal LORENZ

---

---

---

---

---

---

---

---

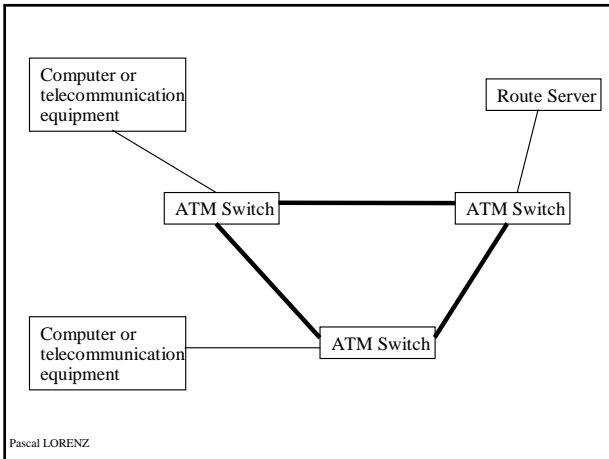

---

---

---

---

---

---

---

---

### WATM (Wireless ATM)

- management of the QoS is difficult because the way change continually
- new model such as MPOWA (Multi Protocol Over Wireless ATM)
- introduce mechanisms such as FEC (Forward Error Correction), ARQ (Automatic Repeat Request)

Pascal LORENZ

---

---

---

---

---

---

---

---

### Mobile and Wireless ATM (MWATM)

- **Require ATM switches with mobility features. (Mobility enhanced ATM switches).**
- **Mobility specific: Signaling, Location management, mobility management, security management and connection admission control**
- **Mobility specific issues should be taken into account.**

Pascal LORENZ

---

---

---

---

---

---

---

---

- ATM is a good solution but
- Disadvantage of ATM
  - Big overhead
  - Complex and expensive
  - expensive support of VC (time, grow exponentially)
  - support of IP is complex

Pascal LORENZ

---

---

---

---

---

---

---

---

## Mechanisms allowing QoS

- 1996: proprietary solutions such as Tag Switching (Ipsilon), IP Switching and Net Flow Switching (Cisco), ARIS (IBM), IP Navigator (Cascade), ...
- Signaling (control, management) -> routers
- Data -> switches

Pascal LORENZ

---

---

---

---

---

---

---

---

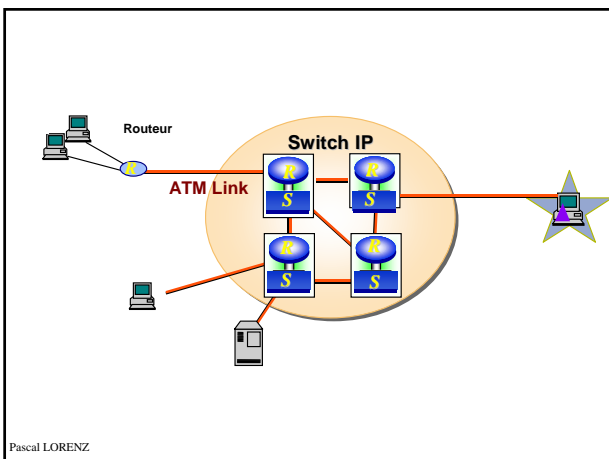

Pascal LORENZ

---

---

---

---

---

---

---

---

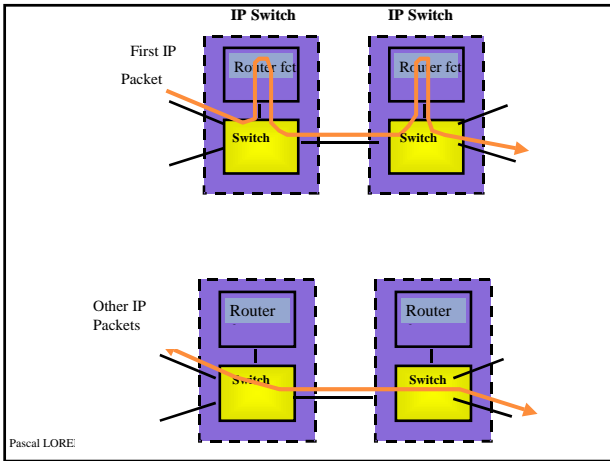

---

---

---

---

---

---

---

---

- The control plane of ATM has been transferred to the IP layers
  - IP: routing, signaling and the management of switching tables (20% traffic)
  - ATM or Ethernet: only the fast forwarding at level 2 (80% traffic)
- Pascal LORENZ

---

---

---

---

---

---

---

---

Transport Layer	IntServ, RSVP, DiffServ
Network Layer (IP)	MPLS
Data Link Layer (Ethernet, FR, ATM, PPP)	
Physical Layer (Sonet/SDH, optical fiber, 802.17: Resilient Packet Ring)	

Pascal LORENZ

---

---

---

---

---

---

---

---

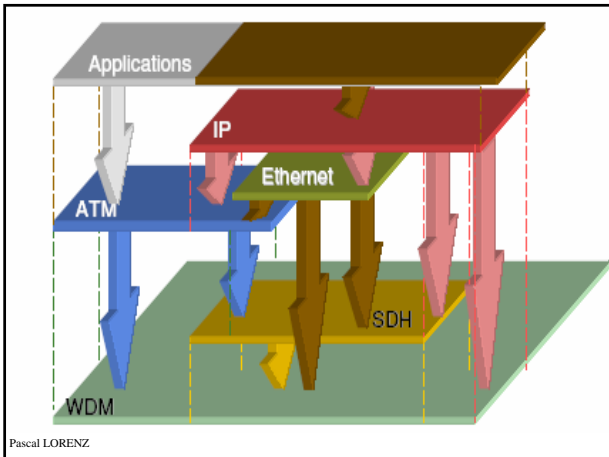

---



---



---



---



---



---



---

### MPLS (Multi Protocol Label Switching)

- Packet forwarding is based on labels
- Labels (4 octets) are assigned when the packets enter into the network
- The assignment of a packet to a FEC (Forwarding Equivalence Class) is done just once when the packet enters in the network at the ingress node, all packets with the same destination use a common route
- At the egress node, the label is removed
- The label is inserted between the layer 2 header and the IP header

Pascal LORENZ

---



---



---



---



---



---



---

- Existing protocols (BGP, RSVP, ...) are extended to enable to piggyback the MPLS labels
- Label switching enables better IP/ATM integration
  - Can encode one or two labels into the VPI/VCI field when 2 ATM-LSR are connected
  - IP protocols are switched instead of routed
  - IP can keep RIP, OSPF or BGP protocols

Pascal LORENZ

---



---



---



---



---



---



---

- MPLS nodes (LSR or Label Switching Router) forward packet/cell based on the label value.
- LSR: only switching and no more routing
- Label switching is a packet forwarding
- MPLS combines L3 routing (IP) and L2 forwarding (ATM with VPI/VCI or Ethernet with a shim label between the MAC and the VLAN addresses (switched Ethernet))
- LSR can implemented DiffServ: DiffServ over MPLS

Pascal LORENZ

---

---

---

---

---

---

---

---

- A LSP (Label Switched Paths) is a sequence of routers
- LDP (signaling protocol): manages the information exchange between the LSR to establish the LSP and associates a FEC to each LSP
- A LSR sent periodically a LDP Hello Message
- Can introduce path protection/restoration: alternate route

Pascal LORENZ

---

---

---

---

---

---

---

---

- Can use RSVP as Label Distribution Protocol
- CR-LDP (Constraint-based Routing LDP): the LSR establish LSPs satisfying to a set of constraints
- MPLS supports IP QoS models
- Can be used to build VPN
- Support all types of traffic
- Can define a trunk for each pair of ingress/egress router OR for each CoS

Pascal LORENZ

---

---

---

---

---

---

---

---

MPLS is able to any IP-compatible link layer technology

- GMPLS: integrate ATM, Ethernet, FR, TDM, optical networks. Label can be a slot, a lambda, a fiber
- Can do traffic engineering (enable to control the network resources and not only the input load to enable the performance optimization): network, structural, behavioral and simulation models are necessary => CR-LDP
- Traffic engineering must be implemented as an automatic control system

Pascal LORENZ

---

---

---

---

---

---

---

---

- MPLS:
  - traffic engineering
  - QoS
  - VPN, overlay
- MPLS same security than Frame Relay
- Core : 40 Gb/s - Edges: do classification
- MPLS is an extension of the control level
- [layer 2 header – MPLS header – IP header]
- RSVP over MPLS (reservation for a SET of same flows)

Pascal LORENZ

---

---

---

---

---

---

---

---

## Real time Transport Protocol and Real Time Control Protocol

- RTP: functions for real time applications
- RTCP: used for supervision and control information
- => QoS for voice and movies without jitter

Pascal LORENZ

---

---

---

---

---

---

---

---

### Reservation of Resource

- First Internet generation: RSVP (supervision packet via a routing algorithm)
  - IP generation of UMTS: COPS (supervision packet via a central command site)
- ⇒ Network management level for: traffic, mobility, QoS, security, resource, portability and compability management  
...

Pascal LORENZ

---

---

---

---

---

---

---

---

### Ressource ReSerVation Protocol

- Signaling protocol to establish unidirectional flows in IP networks
- RSVP is used by routers to deliver QoS
- RSVP request : reserve resources in each node along a path
- RSVP sends periodic refresh message to maintain the state along the reserved paths(s)
- The bandwidth is reserved for a given flow
- Require resources reservation and releasing at regular intervals

Pascal LORENZ

---

---

---

---

---

---

---

---

- Establishment/maintain of unidirectional flows in IP networks through the messages PATH and RESV
- RSVP messages are encapsulated inside IP packets
- Refresh regularly the flow (soft state solution). Default refresh period = 30 seconds
- Supports MPLS and layer 4 flows
- Support multicast and unicast traffics

Pascal LORENZ

---

---

---

---

---

---

---

---

- Signaling transport can be done by COPS (Common Open Policy Service):
  - exchange between a policy server (Policy Decision Point) and a edge router (Policy Enforcement Point): RAP (Resource Allocation Protocol) IETF Standard
  - SNMP ->COPS
  - MIB->PIB (Policy Information Base): set of classes
  - variable->object
  - UDP->TCP
- In the PEP, we can found LPDP (Local PDP)
- Consult the PDP of the operators: to know the best network, best price of the communication

Pascal LORENZ

---

---

---

---

---

---

---

---

---

---

- 2 policy management:
  - outsourcing policy model : PDP decides if a request can be accepted or not (ex RSVP request)
  - provisioning policy model: PDP decides what politic should be installed in routers
- PDP include bandwidth, security and mobility brokers, authentication servers, billing ...
- COPS can use IPsec for authentication, VPN and secure communications

Pascal LORENZ

---

---

---

---

---

---

---

---

---

---

- PDP is connected to
  - LDAP server (accept or not a new user)
  - PIB (base with all politics)
  - Bandwidth broker (manage the available resources)
  - Mobility broker
  - Security broker
- For example: can give a priority to Web access, high priority for Email and video  
 =>Email is premium, Web is BE

Pascal LORENZ

---

---

---

---

---

---

---

---

---

---

## IntServ

- Based on traffic control mechanisms
- Signaling protocol: RSVP
- Reservation at the router level
- Poor scalability: the amount of state increase proportionally with the number of flows
- Problems:
  - all routers must have RSVP
  - there is no policy for the reservation control
  - stations must support signaling

Pascal LORENZ => small networks

---

---

---

---

---

---

---

---

## Classes of Service for IntServ

- Guaranteed Service (Premium service): application required fixed delay bound (CBR, RT-VBR)
- Controlled-Load Service (Olympic service): applications requiring reliable and enhanced best-effort service (NRT-VBR, GFR, ABR)
- Null service: no respect of time constraints (UBR), but a better best-effort service

Pascal LORENZ

---

---

---

---

---

---

---

---

## DiffServ

- DiffServ is a relative-priority scheme
- Signaling protocol: SLA
- Specify contracts for few traffic classes
- IP Packets are classified and marked at the network ingress routers to create several packet classes
- Type of service is marked inside each IP packet
- DiffServ scalability comes from the aggregation of the traffic
- Utilize aggregate classification state in the core of the network
- Share the bandwidth => hierarchy of the different flows

Pascal LORENZ

---

---

---

---

---

---

---

---

- Work with existing applications
- Similar as MPLS, but more adapted for MAN
- Complex mechanisms are implemented only on boundary nodes
- Complexity depends on the number of different services
- SLA between the client and the provider which specifies for each service the amount of traffic that can be sent

Pascal LORENZ

---

---

---

---

---

---

---

---

### Classes of Service for DiffServ

- Expedited Forwarding (Premium service): fixed bit rate between source and destination -> CBR, RT-VBR
- Assured Forwarding (Olympic service): bursty service, no QoS guaranteed but low loss probability -> ABR, GFR, nrt-VBR
- Bulk Handling: service such as file transfer or mail when no other packets needs to be transmitted-> UBR

Pascal LORENZ

---

---

---

---

---

---

---

---

- DiffServ is more easy (less complex) to be implemented than IntServ, but give less accurately (less QoS flow differentiation) to the flows
- DiffServ: located in the core of the network between the routers
- IntServ: periphery of the networks. Work on micro-flows. Complex, "hard" approach for QoS.
- LAN: IntServ
- MAN: DiffServ (or IntServ)
- WAN: MPLS

Pascal LORENZ

---

---

---

---

---

---

---

---

- DiffServ is an evolution of IP service: load control at aggregate level by the network and not at flow level by TCP
- MPLS is another evolution of IP service: generic connection orientation, increase of routing functionalities

Pascal LORENZ

---

---

---

---

---

---

---

---

## QoS in Wireless Networks

Pascal LORENZ

---

---

---

---

---

---

---

---

## Embedded Internet

- Telephony: wired, wireless, cellular
- Internet: fixed, wireless, mobile
  
- Seamless access
- Location independent access
- ISP independent access
- => a common, flexible IP-based core network
- => different access technologies : horizontal (intra-system) and vertical (inter-system)

Pascal LORENZ

---

---

---

---

---

---

---

---

- Global Internet: GEO, MEO, LEO
  - 3G: UMTS, CDMA2000, ...
  - 2G: GSM, GPRS, EDGE, PDC, ...
  - Hot Spots: WiFi
  - PAN: Bluetooth, Ad Hoc, ...
  - Wired networks: ADSL, PSTN, ...
- => Multimedia mobile applications will create an united common platform that incorporate different services.
  - => QoS (time, bandwidth, reliability, ...) and security problems within heterogeneous networks

Pascal LORENZ

---

---

---

---

---

---

---

---

---

---

## QoS

- Terminals (batterie (hydrogen, supercondensator, ...), screen size, processor, ....)
- Blind spots
- Handover
- Each wireless networks offer different QoS

Pascal LORENZ

---

---

---

---

---

---

---

---

---

---

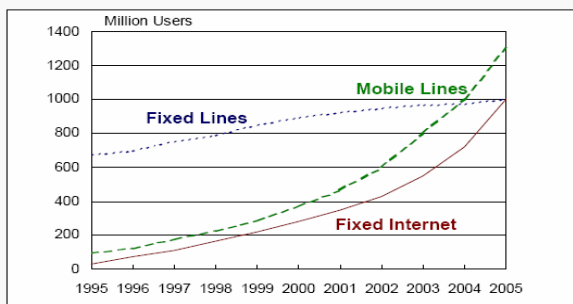

Pascal LORENZ

---

---

---

---

---

---

---

---

---

---

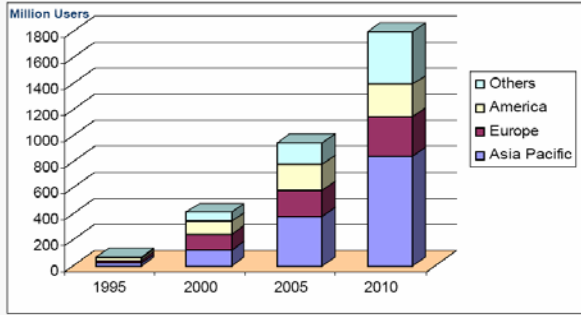

Pascal LORENZ

---

---

---

---

---

---

---

---

- Cellular networks
- Mobile and Wireless networks
- Data transmission networks
- Satellites networks

Pascal LORENZ

---

---

---

---

---

---

---

---

- wave radio-electrical: large distances, penetrate the buildings.
- wave infrared: small distance, do not penetrate the buildings.
- micro-wave: frequency upper to 100 MHz, distances 80 km, do not penetrate the buildings.
- light wave : lasers are quickly absorbed by the rain or the snow

Pascal LORENZ

---

---

---

---

---

---

---

---

## Bringing the Internet to the RF world and vice-versa

- Long and valuable history of “pre-internet” wireless engineering of applications solving problems like mobility, scale, location, real-time transport
- Long and valuable history of Internet of wired systems with applications solving problems like routing, addressing, multimedia transmission

Pascal LORENZ

---

---

---

---

---

---

---

---

## What Are The Drivers?

- **Transparent Access**
  - End to end access to the Internet through a number of different end systems (PC, handhelds, cellular devices, palm pilot, etc.)
- **Quality of Service (QoS)**
  - IP QoS essential for next generation services
  - Multimedia content over the Internet necessitates differentiation of traffic classes
  - Creates a need for different delivery mechanisms:
    - consumers
    - commercial users
    - content providers

Pascal LORENZ

---

---

---

---

---

---

---

---

## Mobile Internet Applications

- **Financial**
  - Stock quotes and notification
  - Financial news
  - Stock trade engine
  - Banking engine
- **Mobile travelers**
  - Weather services
  - Address finder
  - Route planner
  - Restaurant and hotel finder
  - City guide and Air/Train/Bus information

Pascal LORENZ

---

---

---

---

---

---

---

---

## Mobile Internet Applications (Cont.)

- **Mobile Community**
  - Community chat
  - Secrets sharing engine
- **Mobile entertainment**
  - Games
  - Music sharing
  - Picture messaging
- **Mobile Personal Internet management**
  - E-mail
  - Net meeting
  - Calendar and address book

Pascal LORENZ

---

---

---

---

---

---

---

---

## Mobile, Satellite and Personal Communications - 4th Generation

- **Satellite Broadband**
  - Satellite Universal Mobile telecommunication System (S - UMTS)
  - S - DVB
- **Broadcasting**
  - Digital Video Broadcast (DVB – T & H) Digital Video Broadcasting & Handheld
  - Digital Audio Broadcast (DAB) Cellular Digital Audio Broadcasting
  - (T & S) Digital Multimedia Broadcast (DMB) Terrestrial & Satellite
  - Enhanced Data rates for GSM Evolution (EDGE)
  - General Packet Radio System (GPRS)
  - GSM

Pascal LORENZ  
UMTS and UMTS++

---

---

---

---

---

---

---

---

## Broadband Radio Access IP based Networks Projects

- Access network is based on end - to - end IP real time and non real time services
- Application is in Suburban, Urban, in buildings and home cells
- Coverage is in campus areas, conference centers, railway stations and airports (hot spots)
- pervasive computing/ambient network relies on ubiquitous computing (computing facilities everywhere)
- Provides local and global mobility management and QoS through IP services
- Mobility need to be included in QoS architecture, Differentiated and integrated services

Pascal LORENZ

---

---

---

---

---

---

---

---

## Mobile and Wireless Standardization Forums

- ITU - UMTS ([www.itu.org](http://www.itu.org))
- 3rd Generation Partnership Project (3GPP) - <http://www.3gpp.org/>
- European Telecommunications Standards Institute (ETSI)
- Wireless Application Protocol (WAP) - [www.wapforum.org](http://www.wapforum.org)
- HTML --> WML --> WAP
  
- Mobile Wireless Internet Forum (MWIF) ([www.mwi.org](http://www.mwi.org))
- Information Society Technologies (IST), Wireless Information Society 4th generation
- [http://www.cordis.lu/ist/ka4/mobile/barc\\_tab.htm](http://www.cordis.lu/ist/ka4/mobile/barc_tab.htm)
- <http://www.infowin.org/ACTS/IST/>
- <http://www.etsi.org>
- <http://www.istd.org>
- <http://www.ipv6forum.com/>
- Cellular IP < draft-ietf-mobileip-cellularip-00.txt>
- Requirements on mobile IP from a cellular perspective < draft-ietf-mobileip-cellular-requirements-02.txt>
- <http://www.atmforum.com>

Pascal LORENZ

---

---

---

---

---

---

---

---

---

---

## Multiple Access Techniques

- 1G: FDMA (analogical)
- 2G: TDMA (numerical)
- 3G: CDMA
- 4G: OFDM (Orthogonal Frequency Division Multiplexing)

Pascal LORENZ

---

---

---

---

---

---

---

---

---

---

## Satellite Transponders

- LEO  
(Low Earth Orbit) use the Ka band
  
- MEO  
(Medium Earth Orbit),
  
- GEO  
(Geostationary Earth Orbit).

Pascal LORENZ

---

---

---

---

---

---

---

---

---

---

**Satellites :**

- **Ku band (10 GHz to 18 GHz),**
- **C band (4 GHz to 6 GHz) for the connections between terrestrial stations and satellites.**
- **Ka band (20 GHz to 30 GHz) not very used**
- **V band (40 GHz to 50 GHz) futures applications**

Pascal LORENZ

---

---

---

---

---

---

---

---

**LEO (Low Earth Orbit),  
between 500 and 2000 km.  
Communication delay: 0.01 second and  
rate of 155 Mbit/s.**

**To cover the world: 50 satellites, one  
satellite covers the skylink in 15  
minutes.**

Pascal LORENZ

---

---

---

---

---

---

---

---

**- LEO at 800 MHz offer 300 kbit/s rate :  
send messages and for localization.  
GPS (Global Positioning System).**

**- LEO at 2 GHz offer 10 kbit/s rate :  
telephony.**

**- LEO at 20 to 30 GHz offer 155 Mbit/s  
rate: multimedia applications.**

Pascal LORENZ

---

---

---

---

---

---

---

---

**-Iridium (Motorola) is composed by 66 satellites located at an altitude of 780 km and by 6 emergency satellites**

**- Globalstar (France Telecom, Daimler-Benz Aérospatiale) is composed by 48 satellites located at an altitude of 1414 km and by 8 emergency satellites.**

Pascal LORENZ

---

---

---

---

---

---

---

---

**- Teledesic (Microsoft and de Craig McCaw) . It will be composed by 288 satellites located at an altitude of 1375 km with a upload rate of 2 Mbit/s and an rate of 64 Mbit/s for download.**

Pascal LORENZ

---

---

---

---

---

---

---

---

**-Skybridge (Alcatel Space) is composed by 80 satellites located at an altitude of 1469 km**

**- will use the Ku band.**



Pascal LORENZ

---

---

---

---

---

---

---

---

- MEO are located at an altitude of between 5000 and 20000 km and the communications delay are 0.1 second.
- A communication can remain one hour . 12 satellites are necessary to cover all the earth. (ICO systems)

Pascal LORENZ

---

---

---

---

---

---

---

---

- GEO:  
36600 km and the delay are 0.27 second (round).  
Duration: 15 to 20 years and 3 satellites can cover all the world.
- Spoofing: send a quick acknowledgement, equipment continue the transmission. The errors management are done later.
- VSAT (Very Small Aperture Terminal) rate of 50 Mbit/s.  
Antenna has 1 meter diameter.

Pascal LORENZ

---

---

---

---

---

---

---

---

- Pico-satellite: 1 kilo, 340 km
- HEO (Highly elliptical Earth Orbit)
- HAPS (High Altitude Stratospheric Platform):
  - +Proteus airplane (Awards) will offer a bandwidth of 164 kbit/s for a 100 km diameter
  - + Airship at an altitude of 23 km (Sky Station project). Rate of 10 Mbit/s in the 48 GHz band.

Pascal LORENZ

---

---

---

---

---

---

---

---



Pascal LORENZ

---

---

---

---

---

---

---

---

### Telephony

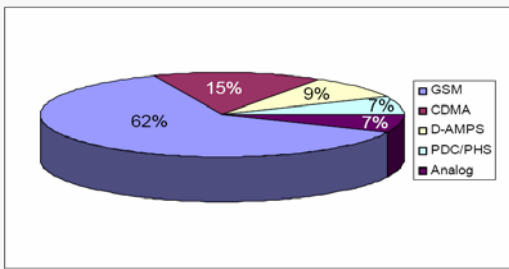

Pascal LORENZ

---

---

---

---

---

---

---

---

### USA technologies :

- **D-AMPS (Advanced Mobile Phone System) 800 MHz or 1900 MHz and based on TDMA,**
- **PCS 1900 (Personal Communication Services) 1900 MHz and based on TDMA,**
- **IS-95 based on CDMA.**
- **IS-136 based on TDMA**

Pascal LORENZ

---

---

---

---

---

---

---

---

**Japan - PDC (Personal Digital Cellular) numerical technology**

**Europe - numerical technology GSM, DCS and PCS**

Pascal LORENZ

---

---

---

---

---

---

---

---

**GSM (Global System for Mobile Communication). Rate of 10 kbit/s.**

**- Two-bands (GSM and DCS), three-bands (900, 1800 and 1900 MHz)**

Pascal LORENZ

---

---

---

---

---

---

---

---

- Femto-cell or Pico-cells for communications with distances between 5 and 50 meter**
- micro-cells for communications with distances between 50 and 500 meter,**
- macro-cells for communications with distances between 0.5 and 10 km.**

Pascal LORENZ

---

---

---

---

---

---

---

---

**Public Land Mobile Network (PLMN)**

- Base Station Subsystem (BSS): manage radio resources

- \* Mobile Station,
- \* Base Transceiver Station (BTS)
- \* Base Station Controller (BSC)

- Network and Switching Subsystem (NSS): manage network resources

- \* Visitor Location Register (VLR) manage the localization of the mobiles
- \* Home Location Register (HLR) contain the information about the subscription
- \* Mobile Switching Center (MSC)

Pascal LORENZ

---

---

---

---

---

---

---

---

- Operation Sub-System (OSS): administration and management of the network and the local administration of the equipment
- Mobile : search of the control channels sent by the different Base Transceiver Station or BTS

Pascal LORENZ

---

---

---

---

---

---

---

---

- **BSC establish the communication with the Mobile services Switching Center or MSC**
- **When the best BTS is chosen, the mobile asks for a logical signaling channel to the BSC which manage the communication synchronization**

Pascal LORENZ

---

---

---

---

---

---

---

---

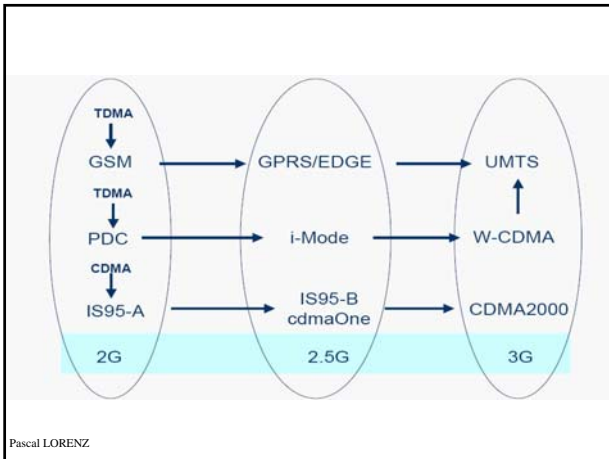

---

---

---

---

---

---

---

---

**2,5G:**

- **GPRS (General Packet Radio Service): rate of 40 kbit/s**
- **packet switching**
- **cost of the communication is based on the amount of data**
- **without modification of the BSS: same frequency of the GSM**
- **reuse the BTS and the BSC**

Pascal LORENZ

---

---

---

---

---

---

---

---

- **NSS: add a gateway GSM and the packet mode**
- **2 additional routers :**
  - **SGSN (Serving GPRS Support Node): manage the resources, the sessions, the taxation and the mobility,**
  - **GGSN (Gateway GPRS Service Node) manage the connections with the IP networks**

Pascal LORENZ

---

---

---

---

---

---

---

---

**2,75 G:**

**EDGE (Enhanced Data rate for GSM Evolution): rate of 150 kbit/s**

**E-GPRS (Enhanced GPRS): apply EDGE to GPRS**

Pascal LORENZ

---

---

---

---

---

---

---

---

**3G:**

**IMT2000 (International Mobile Telecommunication 2000) :**

- integrate in a same network, the cellular network, the wireless network and the data transmission networks.
- services and intelligent terminals (unique number and universal)
- multimedia services : bandwidth on demand.

**2 billions users in 2010**

Pascal LORENZ

---

---

---

---

---

---

---

---

**- UMTS (Universal Mobile Telecommunication System) : 3GPP (Third Generation Partnership Project)**

- ETSI
- Japanese organizations ARIB and TTC
- Korean organization TTA
- American committee T1P1

Pascal LORENZ

---

---

---

---

---

---

---

---

- **VHE (Virtual Home Environment) offers service/ environment portability across networks boundaries between terminals (use of smart card )**
- **rate 2 Mbit/s (City), 144 kbit/s (countryside), de 30 kbit/s (global mobility for satellites)**
- **1885 MHz to 2030 MHz band**
- **2110 MHz to 2200 MHz band**

Pascal LORENZ

---

---

---

---

---

---

---

---

- **CDMA 2000 (USA) is an evolution of the American IS-95 standard,**
- **UWC-136 (USA) based on the GPRS and EDGE technologies and is an evolution of the American IS-136 standard.**
- **UMTS -> UMTS TDD (TD-CDMA)**
- **W-CDMA (Japan, European) -> UMTS FDD**

Pascal LORENZ

---

---

---

---

---

---

---

---

**UTRAN (Universal Terrestrial Radio Access Network) uses the modes:**

- **TDD (Time Division Duplex) :**
- + **temporal multiplexing and 2 Mbit/s rate**
- > **sharing transmission time.**
- + **asymmetrical traffic**
- **FDD (Frequency Division Duplex)**
- + **frequency and codes multiplexing**
- + **380 bit/s rate : large network.**
- + **upload and download traffic use different frequencies**
- + **symmetrical traffic**

Pascal LORENZ

---

---

---

---

---

---

---

---

- **BTS -> node B**
- **BSC -> RNC (Radio Network Controller)**
- **MSC -> UMSC (UMTS MSC)**
- **BSS -> RNS (Radio Network Subsystem)**
- **MS (Mobile Station) -> UE (User Equipment)**

Pascal LORENZ

---

---

---

---

---

---

---

---

- **New frequency and new infrastructures**
- **UMTS: 384 kb/s**
- **3,5G: HSDPA (High Speed Downlink Packet Access) => 2Mbit/s**
- **3,75G: HSUPA High-Speed Uplink Packet Access => 5 Mb/s**
- **4G: 2010 will use the 30 GHz frequency : 300 Mb/s**

Pascal LORENZ

---

---

---

---

---

---

---

---

### IEEE 802 wireless standards

- 802.15 WPAN, since 1999 (RFID, ZigBee, Bluetooth, UWB, Wimedia)
- 802.11 WLAN, since 1990 (WiFi)
- 802.16 WMAN, Wireless Local Loop, since 1999 (WiMax)
- 802.22 WRAN
- There is no single technology that can satisfy all needs . Family of complementary technologies and devices

Pascal LORENZ

---

---

---

---

---

---

---

---

### **Wireless Personal Area Networks (WPAN) IEEE 802.15**

- RFID (Radio Frequency Identification)
  - IEEE 802.15.1 : Wireless Personal Area Network (Bluetooth). Rate 1 Mbit/s, 2400MHz. 10 meters
  - IEEE 802.15.3: High rate 400 Mbit/s WiMedia
- Ultra WideBand (UWB) is a wireless technology for transmitting digital data over a wide spectrum of frequency bands with very low power, WUSB (Wireless USB) => 480 Mb/s
- IEEE 802.15.4: 200 kb/s, communications between toys, sensors (ZigBee), low complexity, low power consumption

Pascal LORENZ

---

---

---

---

---

---

---

---

### **Wireless LAN (WLAN)**

- **IEEE 802.11b (WiFi – Wireless Fidelity): frequency 2.4 GHz, rate 11 Mbit/s, 100 meter, 2 walls CDMA/CA, 14 channels**
- **IEEE 802.11g: 2.4 GHz, 54 Mbit/s**, compatible with 802.11b
- **IEEE 802.11a : 5 Ghz, 54 Mbit/s (WiFi 5), 1997**
- **IEEE 802.11i : security** (EAP: Extensible Authentication Protocol), WEP, TKIP, WPA
- **IEEE 802.11e : QoS**
- **IEEE 802.11f : handover**
- **IEEE 802.11n: power control, High throughput WLAN (400 mb/s), (e+f+i) 2,4 et 5 Ghz**
- pre-n: MIMO (Multiple Inputs Multiple Outputs)**

Pascal LORENZ

---

---

---

---

---

---

---

---

### **New IEEE 802.11 projects**

- 802.11k for radio resource management to achieve optimized use of radio resources
- 802.11r – Fast roaming
- 802.11s – Mesh networks (improving WiFi with AdHoc) => mobile hotspot
- 802.11u – Wireless Interworking with External Networks (WIEN)

Pascal LORENZ

---

---

---

---

---

---

---

---

**Wireless Local Loop (WLL) & WMAN  
(Wireless Metropolitan Area Network)  
IEEE 802.16**

- WiMax standard: 10 Ghz to 66 Ghz, 50 km and 120 Mbit/s  
(Plug & play) => equivalent and compete with DSL, can connect 802.11 hotspots, transmit voice, IP, ... with security
- WiMax-Mobile (IEEE 802.16e ex IEEE 802.20) 3,5 Ghz 1Mbit/s 250 km/h

Pascal LORENZ

---

---

---

---

---

---

---

---

- - **LMDS (Local Multi-point Distribution Service): + bi-directional transmissions point to multi-points**
  - + rate of 1 Gbit/s in the 28 GHz to 31 GHz band
  - + 1 to 2 km distances
  - + directive antenna without shadow area, Rain Fading

Pascal LORENZ

---

---

---

---

---

---

---

---

- MMDS (Multi-channel Multi-point Distribution Service):**
- + unidirectional video
  - + distances 10 km in the 2.5 GHz to 2.7 GHz band
  - +rural areas without CATV.

Pascal LORENZ

---

---

---

---

---

---

---

---

**WRAN (Wireless Regional Area network)  
IEEE 802.22**

Mobile Broadband Wireless Access (MBWA)  
1Mb/s 3,5 Ghz, cell of 1 km with QoS  
Interactive TV => GPS is used to find the  
frequencies

Pascal LORENZ

---

---

---

---

---

---

---

---

- 802.21 is devoted for handoff among different networks and different type of networks (e.g. WiFi, WiMax and cellular systems)

Pascal LORENZ

---

---

---

---

---

---

---

---

- **GSM -> ISDN**
- **GPRS -> Frame Relay**
- **UMTS -> ATM (AAL2)**
- **2nd generation of UMTS and CDMA 2000 -> IP**

**=>Efficient support of Internet-based services is not possible without a core network totally based on IP**

Pascal LORENZ

---

---

---

---

---

---

---

---

## Next Generation Internet

- MPLS, Native IP, Carrier Grade Ethernet
- Unique network: wired and wireless, data, voice
- Problem of TCP/IP: electrical consumption, complexity
- Intelligence in the network: smart, active autonomic networks => autoconfiguration

Pascal LORENZ

---

---

---

---

---

---

---

---

THANK YOU - Question ??

Pascal LORENZ

---

---

---

---

---

---

---

---